

# Efficient and ergonomic delivery



*Store Manager, KIWI, CC Hamar*

For the past few months, the KIWI-branch in Hamar, Norway, has used the pallet rack SpacelInvader, and they have already seen and felt the difference. Even if it has meant change of daily routines, the rack has quickly cut costs and time spent, and eased employees' workload. Store Manager Christian Gulbrandsen shares what SpacelInvader has meant for his business.



Scan QR code or [click here](#) to view video case

## Efficient stock replenishment

When KIWI opens at 7 every morning, fruit, preserves and other products line up in neat rows on the store's many shelves. Organised like this, the arrangements seem like the natural order of things, but before the doors open, the store is alive with employees darting around to make sure the shelves are full and ready for a new day.

Replenishing stock will always be a hectic ordeal, but as Store Manager, Christian Gulbrandsen still sees ways to improve the delivery and handling of goods. Every morning goods arrive from suppliers on pallets packed high, which his employees have to unpack, lift items down from and thereafter distribute on the sales floor.

According to Gulbrandsen, this means many heavy lifts from up high, which makes workflow inefficient and burdensome for his employees. With SpacelInvader's pallet rack measuring 120 centimeters tall only, Gulbrandsen has found a solution to this particular challenge.

## A better working height

"It's about ergonomics, meaning heavy lifts and the strain it is puts on employees who have to work with the pallets we get from food suppliers," Gulbrandsen says. "With SpacelInvader we get a new and better working height."

The lower working height comes from how SpacelInvader works. SpacelInvader lets you double stack pallets. By using the lower pallet as a stabiliser, a rack is inserted on each side of the pallet and together they create a new platform onto which a pallet can be placed. This lets suppliers pack and transport more goods, but also separate items into categories. All while bringing working height down to the optimal 120 centimetres.

Splitting goods into categories not only eases the workload for Gulbrandsen's employees, it also increases their efficiency.

"We save an entire day's resources handling deliveries.

Those eight hours gained we can now use on other tasks"

**Christian Gulbrandsen**  
Store Manager, KIWI CC Hamar



Many daily heavy lifts from up high during replenishment of shelves.



Ergonomic working height with pallets measuring only 120 cm tall.

## A faster turnaround

"Our replenishment of shelves has improved, because our work is now more concentrated," says Gulbrandsen. Pallets with goods can now be customised to the needs of the store, and that speeds up the stocking of shelves.

"I can reduce the number of hours we spend on handling deliveries by about 5%, so that is a definite positive to consider", Gulbrandsen says. "That translates to eight hours per week, so clearly the racks create value".

Goods that are already sorted and packed according to category makes it much easier for Gulbrandsen to unpack his deliveries. To boot, the increased amount of goods he gets delivered each time due to the double stacking of pallets means one less delivery day. Finally, the rack's ability to create space vertically has proven beneficial for his storage capacity during particularly busy holiday periods, where he increases his store supply to meet customer demand.

"We save an entire day's resources handling deliveries. Those eight hours we can now use on other tasks, and we can also increase our floor capacity in the storage area, which we can use to buy and store other products. The rack creates value in several areas of our store", says Gulbrandsen.

## About SpacInvader

The pallet rack, "SpacInvader", is manufactured by SpacInvader, founded in 2015. With its patented design, the rack makes it possible to double stack pallets safely, quickly and efficiently, thereby making it easier to achieve a greater cargo load. The rack is made from aluminum, which makes it lightweight, durable, and easy to recycle.

## Value where it counts

Gulbrandsen feels the SpacInvader rack is worth the change.

"I can save money, help my employees be more effective, and create a more ergonomic working environment"

**Christian Gulbrandsen**  
Store Manager, KIWI CC Hamar

"Of course it means changing your habits, but when you see the value the changes bring and adjusting to the new routines, you realise this is something that optimises all parts of the job, especially the sorting of goods, where we now see fewer heavy lifts. In the end it means less strain on each employee", he says.

Gulbrandsen does not see the additional task of returning the racks to the supply terminal as a cumbersome time waster, either.

"It is quite simple, as long as you follow the instructions printed on the side of the rack. We do not spend a noticeable amount of time on sending the racks back," he says. "Granted, we might spend more time using the racks, but we win it back when handling deliveries."

All in all, the rack helps Gulbrandsen create value in those areas central to his work: the bottom line, the easing of his employees' working day, and getting new items on shelves.

"It lets me save money, helps my employees be more effective, and creates a more ergonomic working environment", Gulbrandsen concludes.



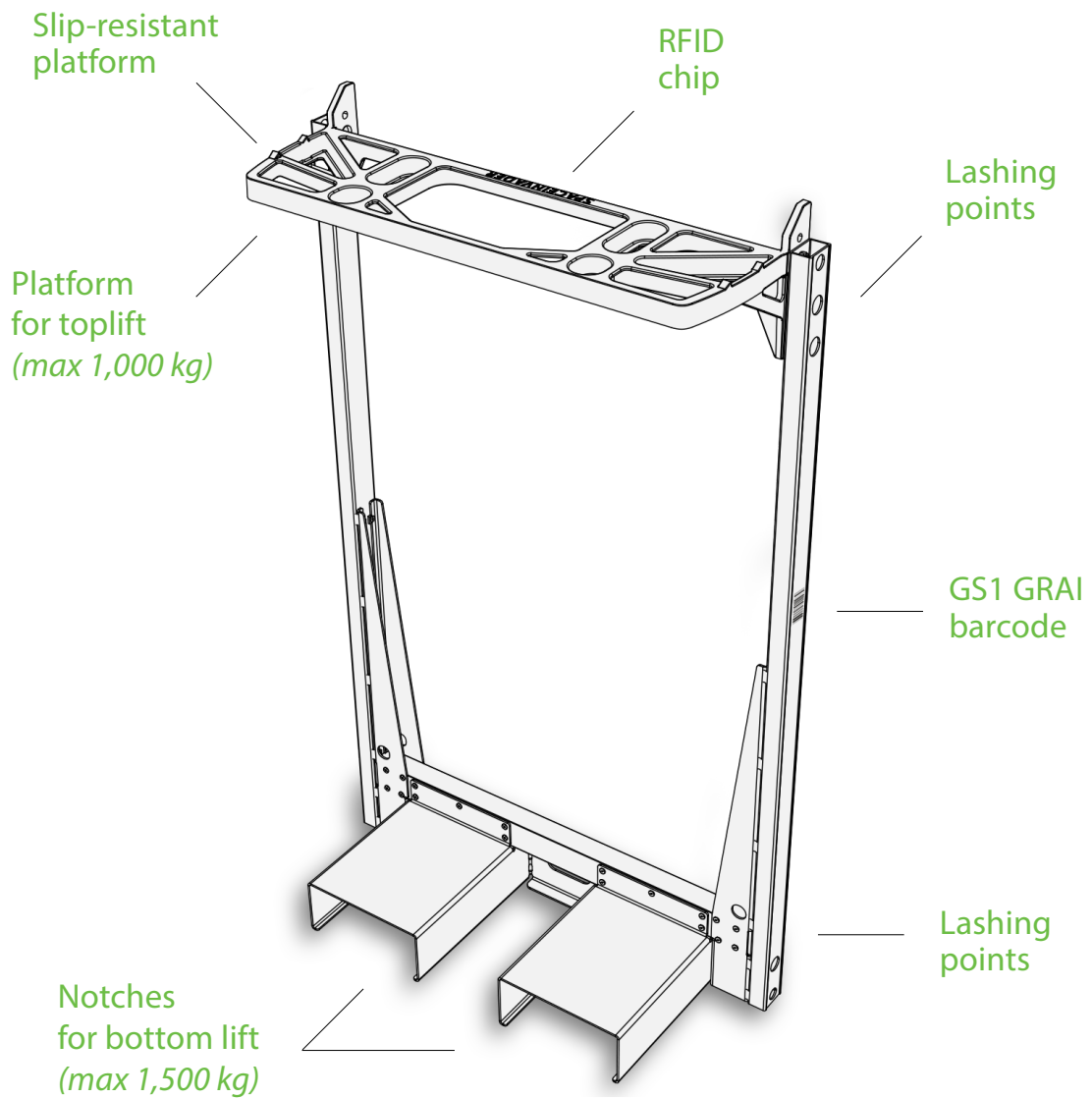

## Specifications

Max weight:	
Top lift	1,000 kg
Bottom lift	1,500 kg
Height	125 cm
Width	79 cm
Weight	9.9 kg
Stacked/pallet	20 pcs/h. 217 cm
Tracking	GS1 barcode RFID chip

